

# PLEASE READ AND FOLLOW ALL WARNINGS



UT1011S  
STRAIGHT #5 SPLINE IMPACT WRENCH

## Read Operating Instructions

Always become familiar with all the instructions and warnings before operating any power tool.



### Always Wear Approved Eye Protection

Impact resistant eye protection should meet or exceed the standards as set forth in the United States ANSI Z87.1, Occupational and Educational Eye and Face Protection. Look for the marking Z87.1 on your eye protection to insure that it is an approved style. For further information, ANSI Z87.1, Occupational and Educational Eye and Face Protection, is available from the American National Standards Institute, Inc., 11 West 42nd Street, New York, NY 10036.



### Hearing Protection is Recommended

Hearing protection should be used when the noise level exposure equals or exceeds an 8 hour time-weighted average sound level of 85 dBA. Process noise, reflective surfaces, other tools being operated nearby, all add to the noise level present in your work area. If you are unable to determine your noise level exposure, we recommend the use of hearing protection.



### Avoid Prolonged Exposure to Vibration

Tools can vibrate during use. Prolonged exposure to vibration or very repetitive hand and arm movements, can cause injury. Stop using any tool if discomfort, tingling feeling or pain occurs. You should consult your physician before resuming use of the tool.



### 90 PSIG Maximum

This tool is designed to operate at

an air pressure of 90 pounds per square inch gauge pressure (90 PSIG) maximum, at the tool. Use of higher air pressure can, and may cause injury. Also, the use of higher air pressure places the internal components under loads and stresses they were not designed for, causing premature failure. The air supply should be clean and dry, preferably lubricated. For best results, drain the moisture from

### WARNING:

Some dust created by power sanding, sawing, grinding, drilling, and other construction activities contains chemicals known to cause cancer, birth defects or reproductive harm. Some examples of these chemicals are:

- Lead from lead-based paints
- Crystalline silica from bricks, cement and other masonry products
- Arsenic and chromium from chemically treated lumber

Your risk from these exposures varies, depending on how often you do this type of work. To reduce your exposure to these chemicals, work in a well-ventilated area and work with approved safety equipment such as those dust masks that are specially designed to filter out microscopic particles.

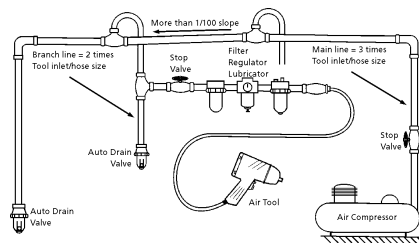

## Description

The Universal Tool professional tools feature alloy steel hammer cases that are machined from solid bar, not drawn or cast. The model number is laser etched on the hammer case for permanent identification. There is a high power to weight ratio, plus 100% parts interchangeability to the equivalent competitor's tool. The features include steel hammer case and three piece housing construction for ease of maintenance. Also included are an adjustable power regulator, ergonomic handle and a sound reducing muffler.



the tool. Tools shall not be used without guards and safety devices as furnished by the manufacturer. Where an air tool is modified or altered, the modifier shall provide the safeguards to enable it to be safely used in the operations intended and to comply with any applicable provisions as contained in ANSI B186.1.

## Tool Installation

Pressure regulators shall be used to limit air pressure to the rated pressure where the supply pressure exceeds the tool's rated pressure. Air hoses and lines shall be relieved of compressed air before being disconnected or disjointed, unless there is automatic valve closing protection at the joint being separated. Synthetic lubricants which can cause deterioration of elastomer seals shall not be used in air systems of air tools.

## Tool Maintenance

It shall be the tool owner's and/or employer's responsibility to assure that tools are maintained in a safe operating condition. Tool maintenance and repair shall be performed by authorized, trained, competent personnel. Tools shall be disconnected from their compressed air supply before repairs are attempted. Repairs shall be consistent with the manufacturer's recommended procedures. Tool, hoses and fittings shall be replaced if unsuitable for safe operation. It shall be the tool owner's and/or employer's responsibility to keep required rating markings and warnings on the tool in legible condition.

## Safety Instructions

The following instructions are furnished as general guidelines for use of your pneumatic tool. They cannot comprehensively cover all possible or conceivable uses of the subject tool. For additional information on the safe use of air tools, we advise you to obtain a copy of ANSI B186.1 Safety Code for Portable Air Tools, available from the following source:

American National Standards Institute, Inc.  
11 West 42nd Street  
New York, NY 10036.

The use of the word "shall" in the following instructions, indicates that adherence to the particular requirement is necessary to conform to ANSI B186.1.

## Tool Application and Usage

Portable tools shall be used only for the purposes intended in their design and within the capacity for which they were intended and rated. It shall be the tool owner's and/or employer's responsibility to instruct each operator in the safe use of

*Read these instructions carefully before attempting to install, operate or service this Florida Pneumatic product. Failure to comply with the instructions could result in personal injury and/or property damage! Retain these instructions for future reference.*

Universal Tool  
A Division of Florida Pneumatic Manufacturing Corporation  
851 Jupiter Park Lane, Jupiter, Florida 33458  
Toll Free 1-800-327-9403

FPMC

**Specifications:**

Shank .....	#5 Spline
Speed.....	5,500 RPM
Working Torque.....	522-1,800 ft. lbs.
Max. Torque .....	2,800 ft. lbs.
Weight.....	22.5 lbs.
Overall length.....	12.5 in.
Average air consumption.....	12.0 CFM
Recommended hose size.....	3/4" I.D.
Air inlet.....	1/2" NPT
Maximum operating pressure .....	90 psi

**Parts Breakdown for UT1011S**
**USE ONLY IMPACT SOCKETS & ACCESSORIES**

Sockets and accessories used shall be of the impact socket type. Always check sockets, retainers and drives regularly for wear or damage and replace whenever necessary

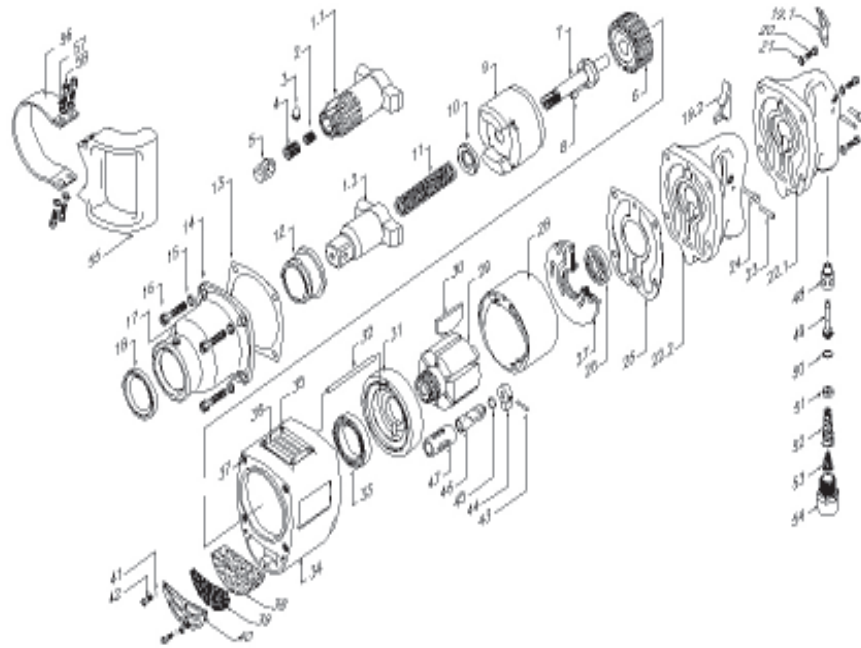
**Replacement Parts for UT1011S**

REF #	PART#	DESCRIPTION
1.1	C-112199	SPLINE ANVIL ASSEMBLY(INC. # 2, 3, 4, 5)
2	C-112202	INNER SPRING
3	C-047620	LOCK BUTTON
4	C-112185	OUTER RETAINING SPRING
5	C-112191	PLUNGER
6	C-136165	COUPLING
7	C-136169	TIMING SHAFT
8	CA-048425	BALL
9	C-136170	DOG
10	C-112190	SPRING SEAT
11	C-136164	SPRING
12	C-112188	CLUTCH HOUSING BUSHING
13	C-112186	CLUTCH HOUSING GASKET
14	C-117545	CLUTCH HOUSING (INCL. # 12)
15	NL8	5/16 NORD LOCK WASHER
16	S-062777	SCREW
17	C-054897	PIPE PLUG
18	CA-088508	SEAL
19.2	C-063747	INSIDE TRIGGER
20	S-062777	SCREW
21	NL8	5/16 NORD LOCK WASHER
22.2	C-119293	INSIDE TRIGGER HANDLE (INCL. # 48)
23	C-114089	TRIGGER STOP PIN
24	C-113758	TRIGGER PIN
25	C-112187	HANDLE GASKET
26	C-068659	BALL BEARING
27	C-136167	REAR END PLATE
28	C-136166	CYLINDER LINER
29	C-112196	ROTOR
30	C-112192	ROTOR BLADES
31	C-136168	FRONT END PLATE
32	C-136161	DOWEL PIN
33	C-066977	BALL BEARING
34	C-112183	MOTOR HOUSING ASSEMBLY (INCL. # 37, 47)
35	N/A	NAMEPLATE RIVET
36	N/A	NAMEPLATE
37	N/A	HELICOIL
38	C-123857	FOAM MUFFLER
39	C-123856	EXHAUST SCREEN
40	C-123855	RETAINING PLATE
41	S-000268	LOCKWASHER #8
42	G-071483	SCREW
43	G-071613	ROLL PIN
44	C-068664	REVERSE LEVER
45	CA-083354	O RING
46	C-106819	REVERSE VALVE
47	C-083339	VALVE BUSHING
48	C-106817	THROTTLE VALVE BUSHING
49	C-106825	THROTTLE VALVE
50	A-043001	O RING
51	C-106818	O RING RETAINER
52	C-088079	THROTTLE VALVE SPRING
53	C-087505	AIR SCREEN
54	C-094354	THROTTLE CAP
55	CA-048548	ASSIST HANDLE
56	C-116388	HANDLE BAND
57	NL6	1/4 NORD LOCK WASHER
58	C-064806	SCREW

**Limited Warranty**

Universal Tool warrants its tools to be free from defects in material and workmanship for one year from the date of purchase. This warranty does not apply to tools which have been abused, misused, modified or repaired by someone other than Universal Tool or its authorized service centers. If a Universal Tool proves defective in material of workmanship within one year after purchase, return it to any authorized service center or to Universal Tool, freight prepaid. Please enclose your name, address and adequate proof of purchase date with a brief description of the defect. Universal Tool will, at its option, repair or replace defective tools, free of charge. Repairs or replacements are warranted as described above for the remainder of the warranty period. Universal Tool's sole liability and your exclusive remedy under this warranty is limited to repair or replacement of the defective tool. There are no other warranties expressed or implied and Universal Tool shall not be liable for incidental, consequential or special damages, or any other damages, costs or expense of repair or replacement as described above.